

PLANT MANAGER	PRODUCTION	PURCHASING & SCHEDULING	 BUSINESS ENTERPRISES LIMITED 24 ARMSTRONG AVE., GEORGETOWN, ON L7G 4R9	PHONE: (905) 873-8509 FAX: (905) 873-9165 TOLL FREE: (877) 260-4309 email: info@brccanada.com	PART NUMBER	DWG NO.	SHEET 1 OF 1	
Q.A.	FOREMAN	CNC		REV	ECN No	REVISIONS	AUTH	BY
CNC PROGRAM #						DRAWN BY: CF		DATE: 2020-06-25
						CHECKED BY: VT		DATE:
						MATERIAL:		TOLERANCES UNLESS OTHERWISE SPECIFIED DIMENSIONAL TOLERANCES ARE: .000 DECIMALS = 1/64 INCHES (STEEL) .000 DECIMALS = 1/64 INCHES (WOOD) ANGULAR TOLERANCES = 0°30'
						DO NOT SCALE DIMENSIONS TO DRAWING.		

DESCRIPTION
ANTITIP BRACKET TO CABINET INSTALLATION

PLEASE SEE ORDER ACKNOWLEDGEMENT FOR FINISHES AND PRODUCT DETAILS

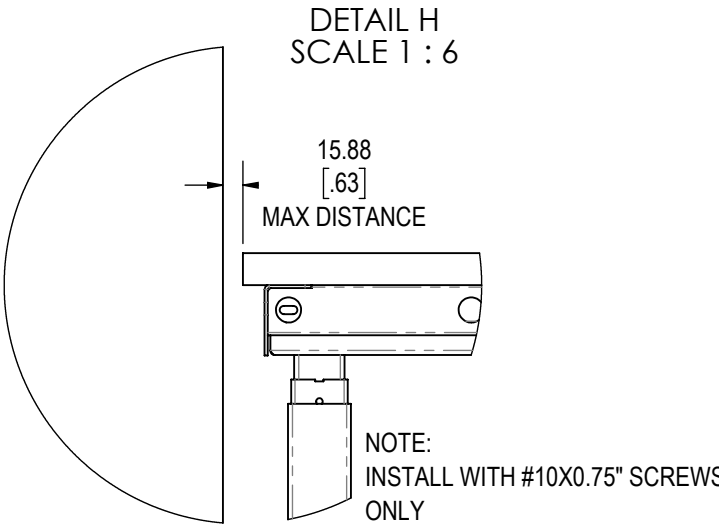
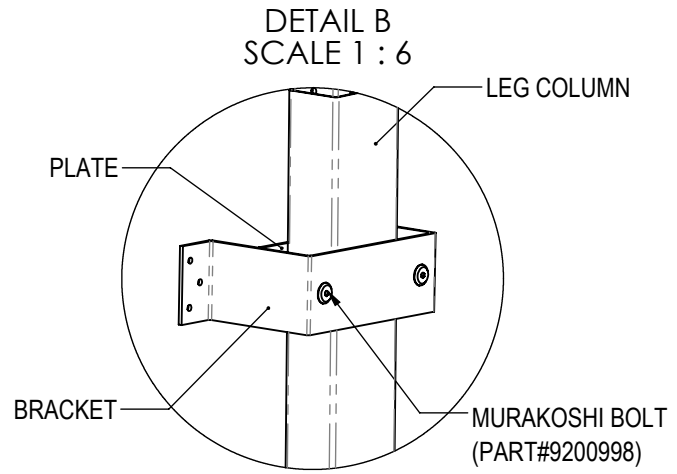

CUST BRACKET QTY-1

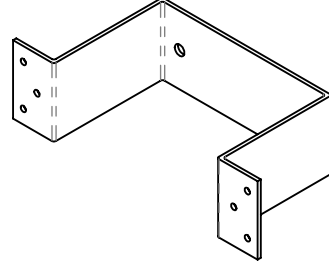

CUST MOUNTING PLATE QTY-1

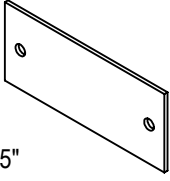

MURAKOSHI BOLT 1/4-20 X2.75" (PART NUMBER#9200998)
MURAKOSHI NUT 1/4-20 0.66" (PART NUMBER#9200018) QTY-2

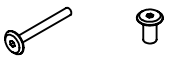
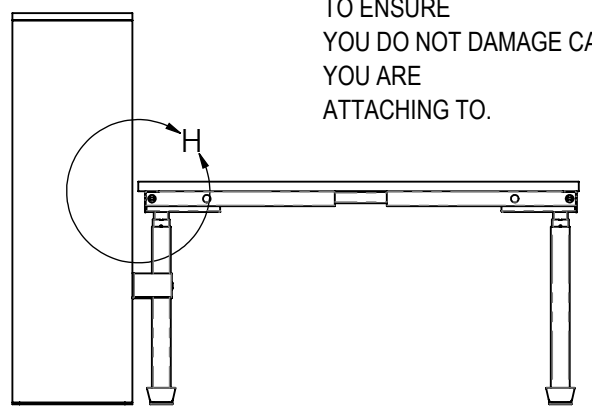
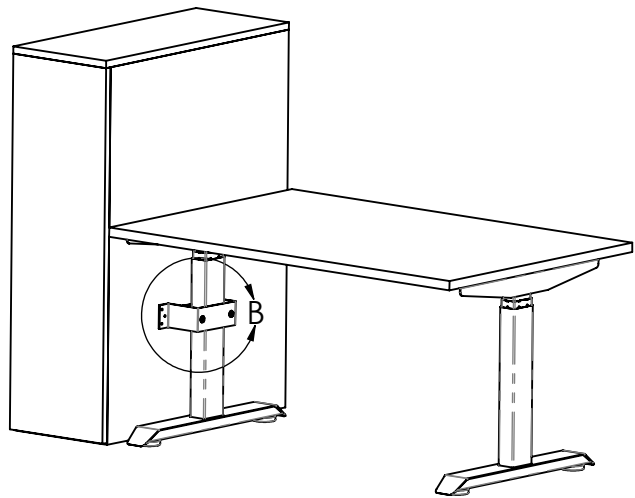
INSTRUCTIONS:
-PLACE BRACKET AROUND LEG AT DESIRED HEIGHT AND SECURE WITH PLATE MURKOSHI BOLTS AND NUTS
-FASTEN TO UNIT WITH SCREWS

By signing herein the Customer or their representative acknowledges that all specifications in the above drawing including dimensions and noted details are correct as presented and they hereby authorize BRC Business Enterprises Ltd. to release the order for production. If details are missing, or if revisions to this drawing are required, do not sign this document. Instead, mark up this drawing accordingly, return to BRC and await a final drawing including the revisions requested in the markup. Should any changes to the specifications or drawing details be required after signing, the Customer must communicate details in writing including a markup of the drawing for reference. Changes of this nature require a new sign off drawing and a new dated authorizing signature. Charges for material or labour incurred may apply. Note: The final signed drawing supersedes any and all details supplied by the Customer on a purchase order, verbally, email, or otherwise. Further it supersedes any BRC acknowledgement sent to the Customer. This drawing contains all final details and a signed copy is the Customers final authority for BRC to proceed with the order and incur costs of production on the Customers behalf.

Final Approval Signature: _____ Date: _____
Name (Please Print): _____
Title: _____
PATH: _____



SAFETY NOTICE

Instability Hazard

Mobile items on casters such as flip top, personal and movable tables of any type and storage items of any type may present an instability hazard if not secured correctly while in use or in storage. Flip top tables or training tables of any type, are inherently more unstable when folded. BRC provides the following guidelines & warnings when using mobile products:

- Lock casters immediately after moving. Do not leave the casters unlocked when in use or in storage.
- Motion may increase the instability of any item with casters. If the wheels hit an obstruction the table's forward momentum often causes overturn, especially if the item is not equipped with wheel extensions. Exercise strong caution while moving these items.
- Use caution when abrupt level changes in the floor are present (such as a doorway or room threshold) as caster failure or tipping may result.
- Do not stand, sit or lean on mobile items for support. They are not intended for this use and personal injury or property damage may result.
- Mobile units that feature height adjustable elements must be lowered to the minimum compressed height when moving to prevent instability. It is also recommended the user remove all computer equipment or other accessories to prevent possible weight imbalance or damage to equipment.
- Failure to follow the guidelines above may result in property damage or personal injury.

Heavy Load

- This product must be anchored to wall to ensure stability & safety.
- It is the owner and installers responsibility to ensure that the wall type and construction is of sufficient strength to carry the loads of any wall mounted products and their contents.
- Failure of the wall and anchors to support all imposed loads may result in property damage or personal injury.
- BRC can provide size and empty weight of its products only. As wall blocking is considered a building construction process, BRC cannot provide recommendations in this respect and cannot be responsible for damage or injury that may occur as a result of improper installation and/or blocking.

Load Bottom Drawer First!

- Operate one drawer at a time.
- Unit may tip if loaded incorrectly.
- Unit should be attached to a wall or other furniture to reduce tipping hazard.
- Always load the heaviest files in the bottom drawer.
- Failure to follow the guidelines above may result in property damage or personal injury.

11/2022