

PLANT MANAGER	PRODUCTION	PURCHASING & SCHEDULING	 BUSINESS ENTERPRISES LIMITED 24 ARMSTRONG AVE., GEORGETOWN, ON L7G 4R9	PHONE: (905) 873-8509 FAX: (905) 873-9165 TOLL FREE: (877) 260-4309 email: info@brccanada.com	PART NUMBER	SHEET 1 OF 1				
Q.A.	FOREMAN	CNC		REV	ECN No	REVISIONS	AUTH	BY	DATE	DESCRIPTION INTEGRATED LEG CREDENZA WITH HAT BRACKET
CNC PROGRAM #									DRAWN BY: JP DATE: 2021-06-15 CHECKED BY: VT DATE: 2021-06-15 MATERIAL: DO NOT SCALE DIMENSIONS TO DRAWING.	TOLERANCES UNLESS OTHERWISE SPECIFIED DIMENSIONAL TOLERANCES ARE: .000 DECIMALS ± 1/64 INCHES (STEEL) .000 DECIMALS ± 1/64 INCHES (WOOD) ANGULAR TOLERANCES ± 0°30'

CUSTOMER:
PO:
BRC:

PLEASE SEE ORDER ACKNOWLEDGEMENT FOR FINISHES AND PRODUCT DETAIL

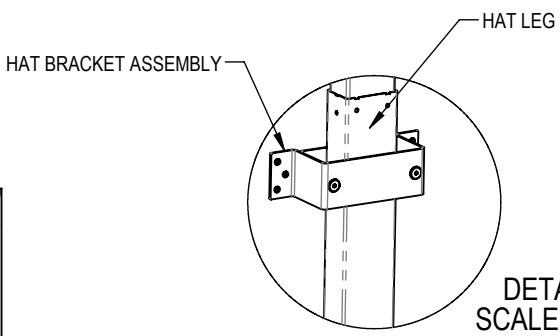
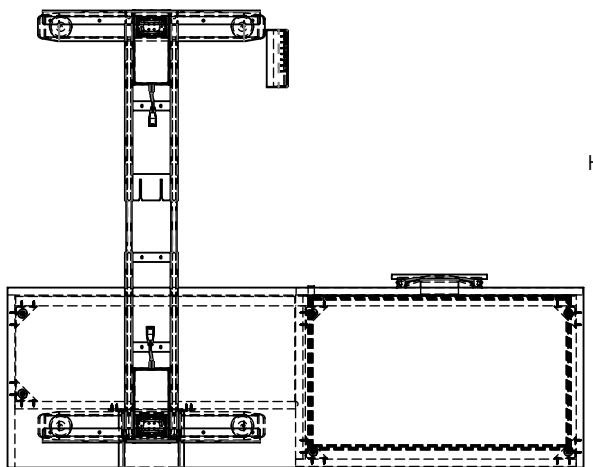

DETAIL A
SCALE 1 : 100

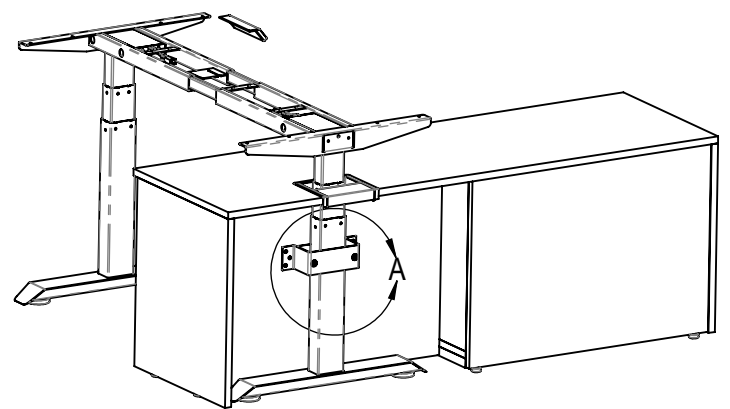
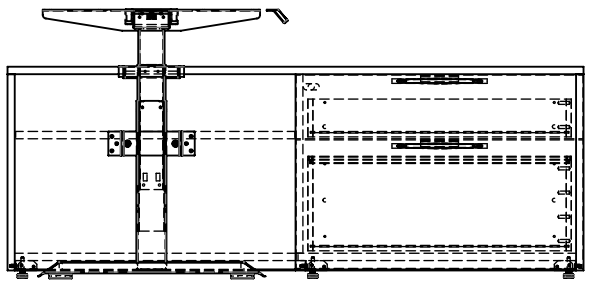
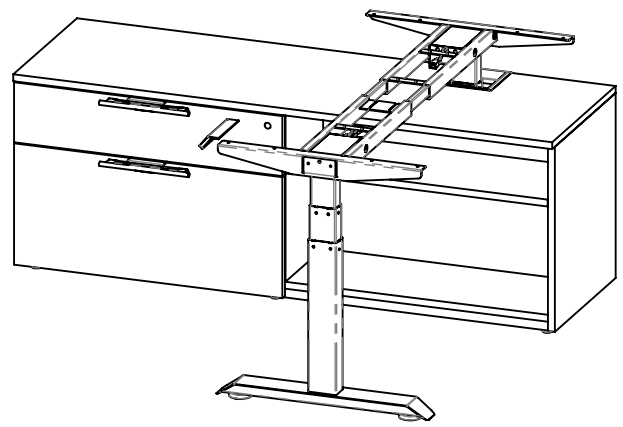

By signing herein the Customer or their representative acknowledges that all specifications in the above drawing including dimensions and noted details are correct as presented and they hereby authorize BRC Business Enterprises Ltd. to release the order for production. If details are missing, or if revisions to this drawing are required, do not sign this document. Instead, mark up this drawing accordingly, return to BRC and await a final drawing including the revisions requested in the markup. Should any changes to the specifications or drawing details be required after signing, the Customer must communicate details in writing including a markup of the drawing for reference. Changes of this nature require a new sign off drawing and a new dated authorizing signature. Charges for material or labour incurred may apply. Note: The final signed drawing supersedes any and all details supplied by the Customer on a purchase order, verbally, email, or otherwise. Further it supersedes any BRC acknowledgement sent to the Customer. This drawing contains all final details and a signed copy is the Customer's final authority for BRC to proceed with the order and incur costs of production on the Customer's behalf.

Final Approval Signature: _____ Date: _____
 Name (Please Print): _____
 Title: _____
 PATH: _____