

3 LEG QUICK CONNECT DESK - UNDER 46"D

ASSEMBLY INSTRUCTIONS

STEP 1: Take out the Framework pieces from carton and extend the outer frame sections.

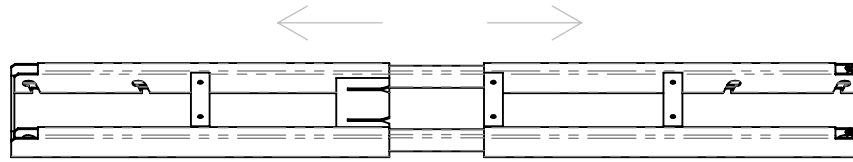

STEP 2: Insert Lifting column into frame keyway leaving pre-installed bolts M6x10 in place. Lock lifting column into frame by installing with M6x12 bolts (x6).

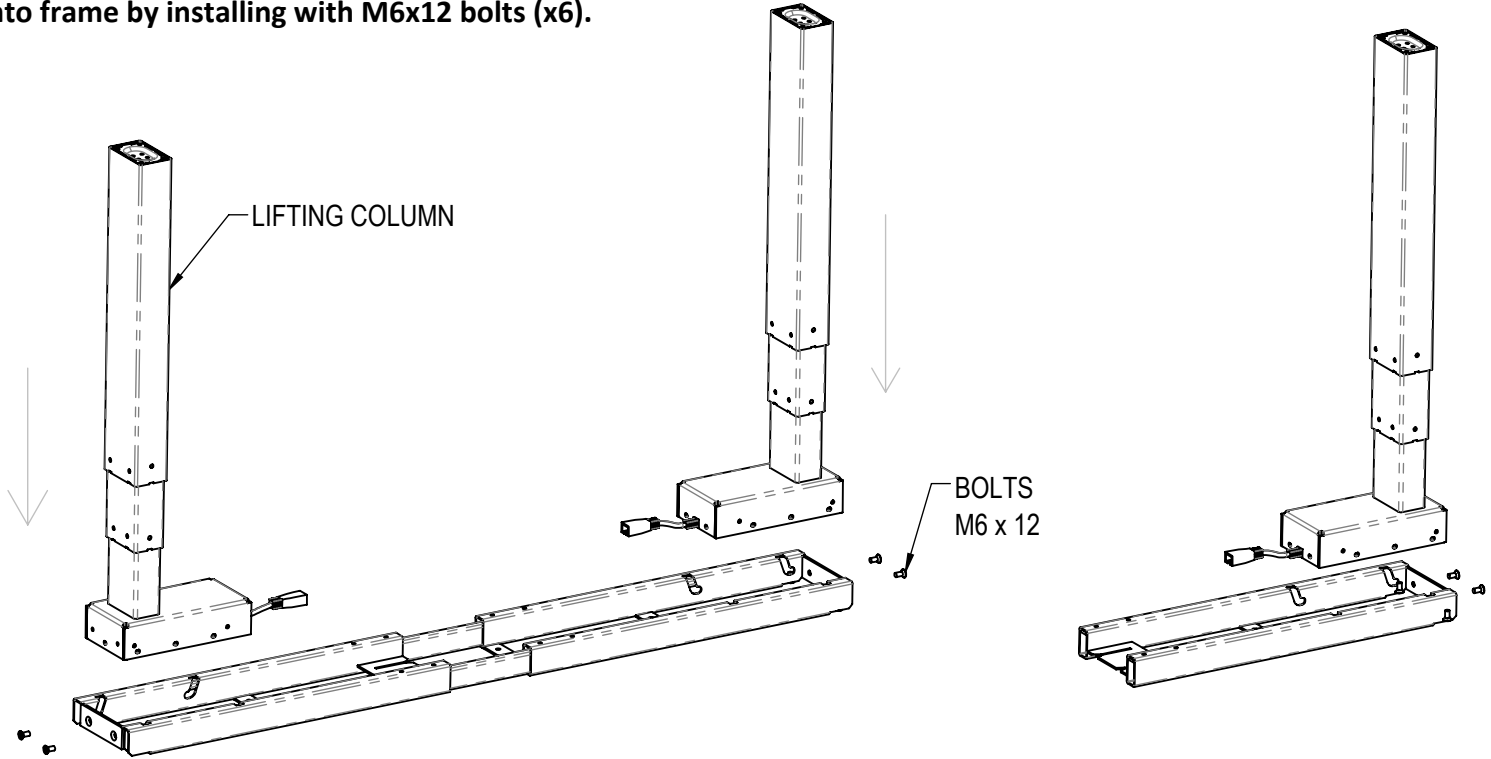

STEP 3: Install leveling glides (x6) to foot (x3).

STEP 4: Install foot (x2) to lifting column and foot (x1) with lifting column. Secure with M6x16 bolts (x12) and star washer (x12).

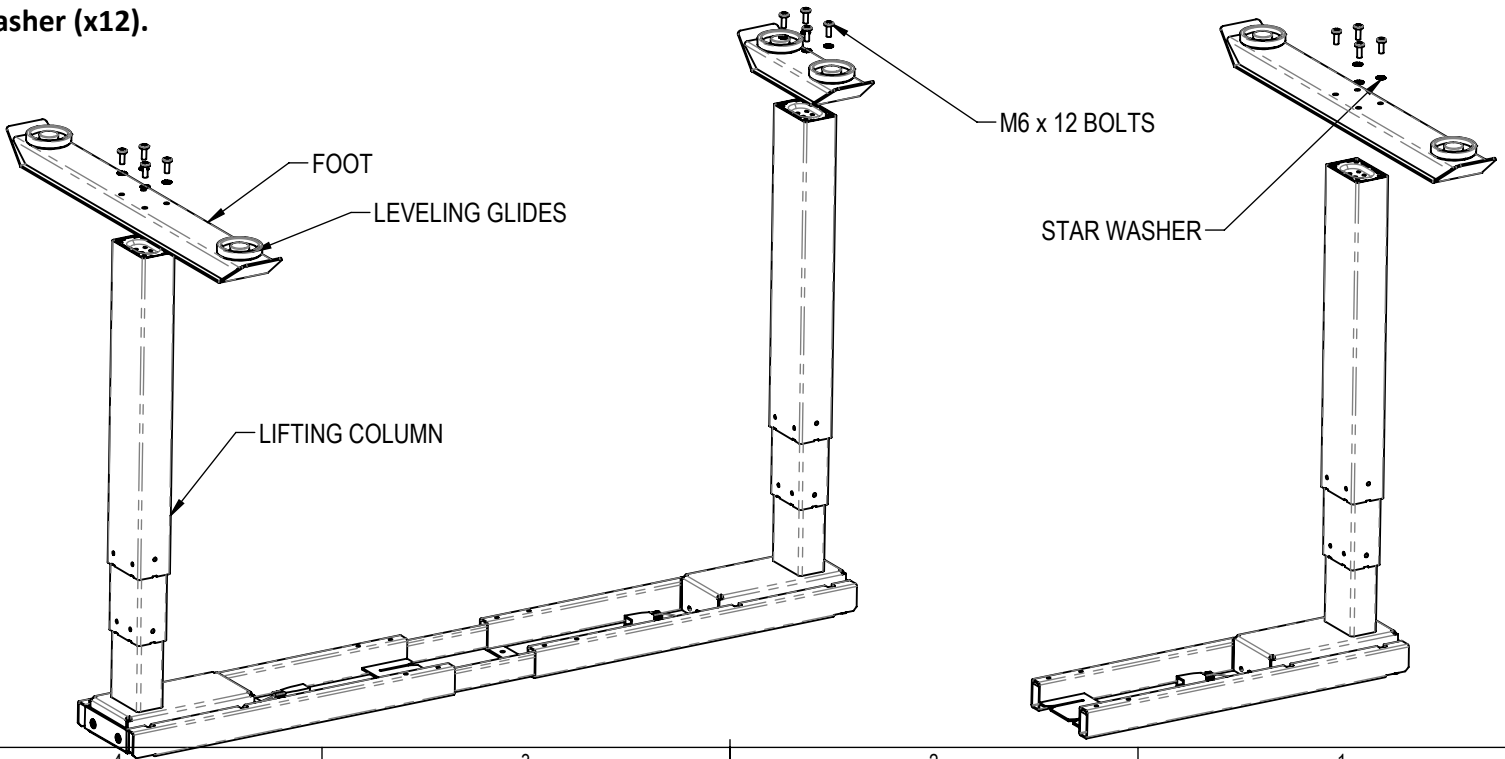

4 3 2 1

3 LEG QUICK CONNECT DESK - UNDER 46"D

ASSEMBLY INSTRUCTIONS

F

STEP5: Install the side support to framework with M6x12 bolts (x6).

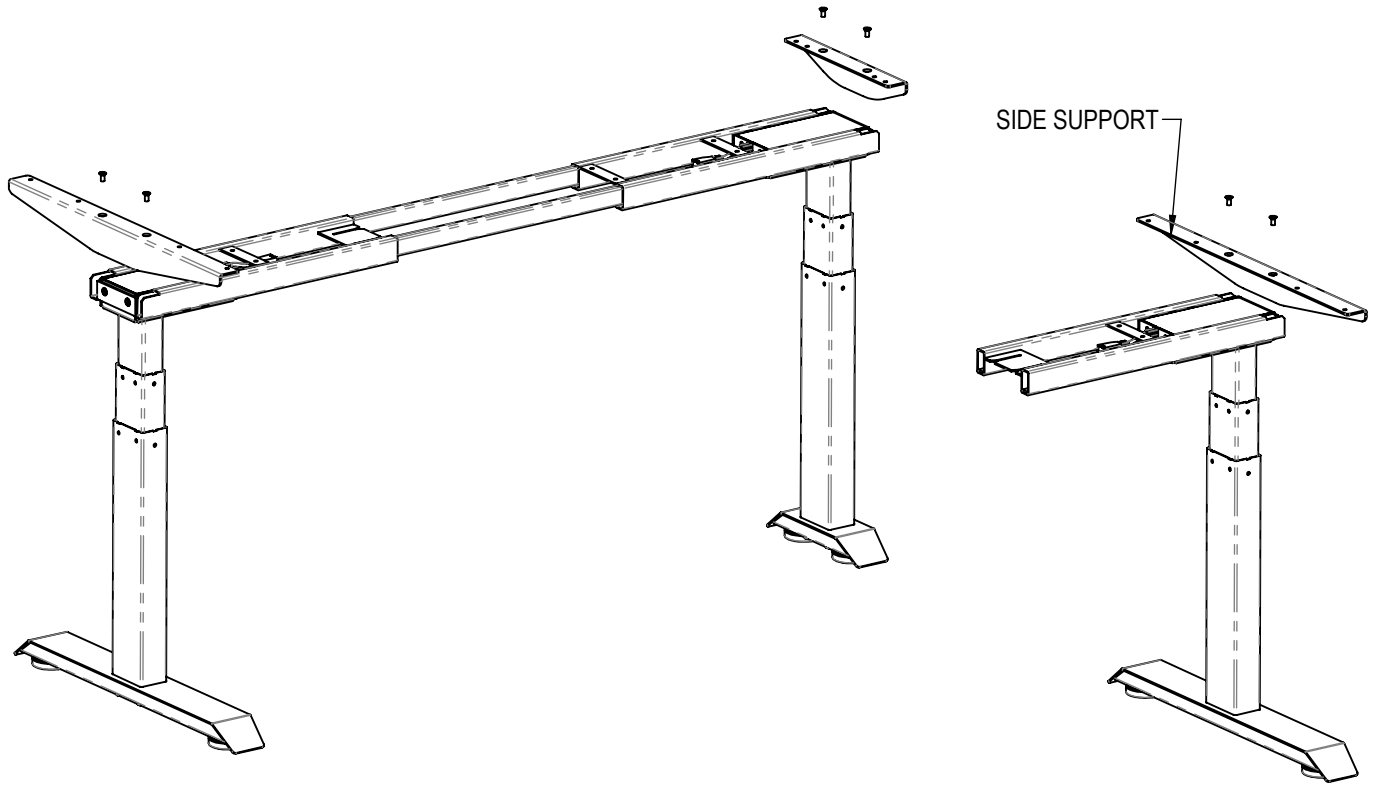

C

STEP 6: Set width of base according to the width of the table top. Tighten M6x10 bolts (x8) to set the base frame to the correct width.

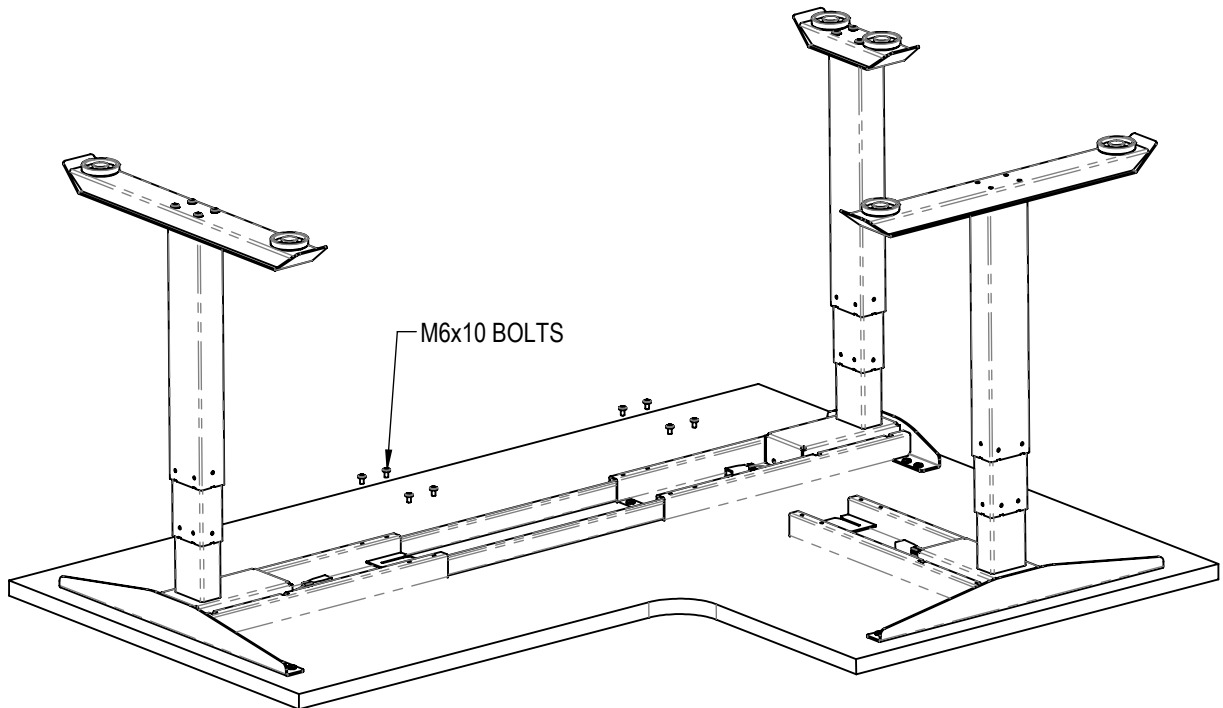

4

3

2

1

3 LEG QUICK CONNECT DESK - UNDER 46"D ASSEMBLY INSTRUCTIONS

STEP 7: Hang the control box on the base. Stick rubber bumper on top of lifting column and extendable tube. Using 1/4-20x3/4 screws (x24) to attach the base to the table top.

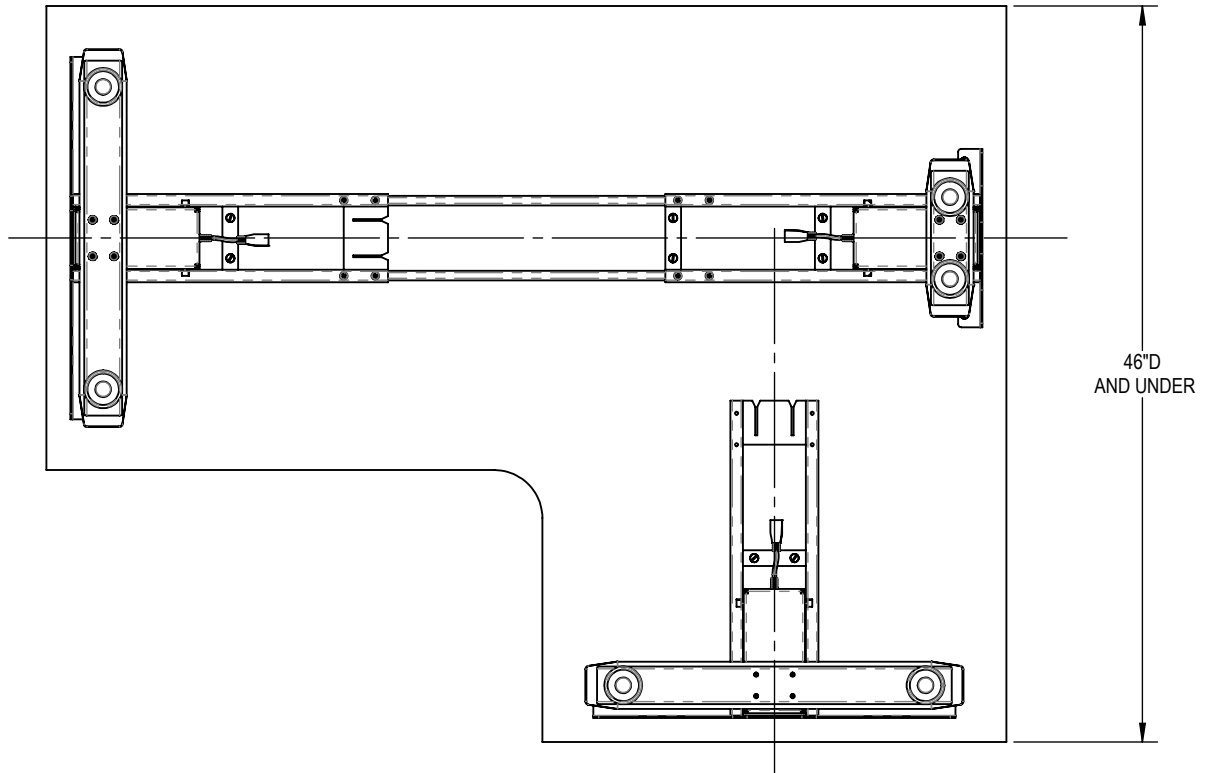
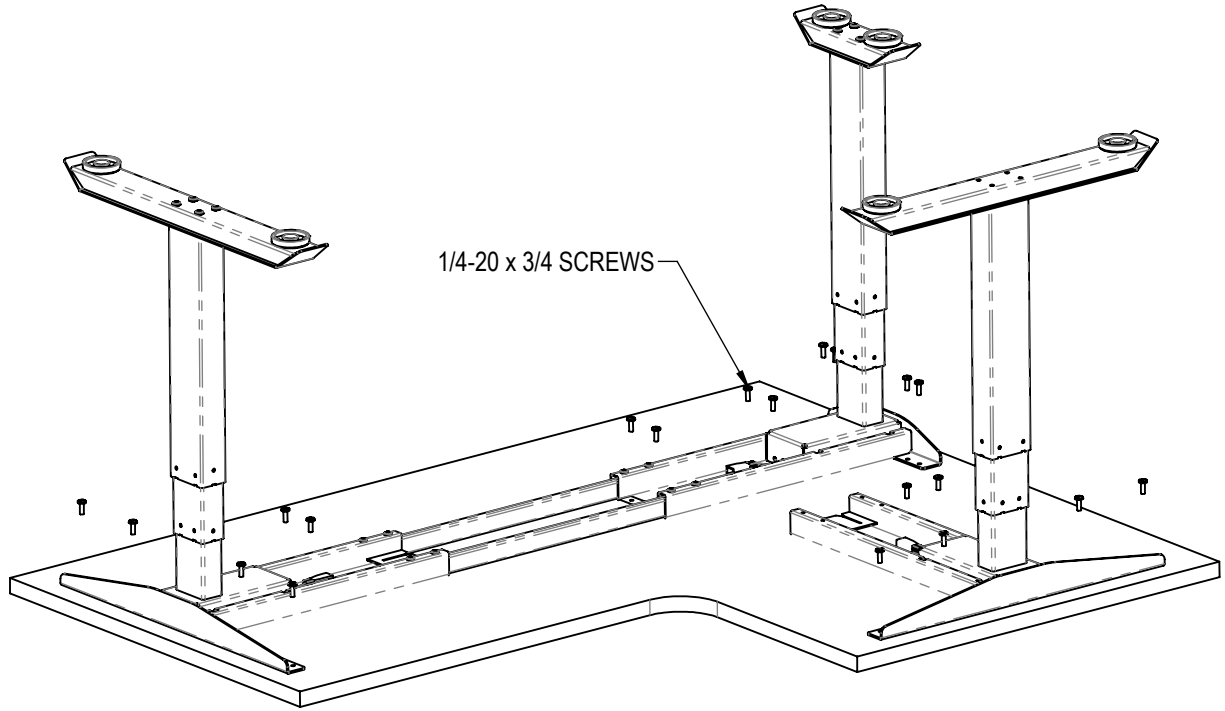

4

3

2

1



SAFETY NOTICE

Instability Hazard

Mobile items on casters such as flip top, personal and movable tables of any type and storage items of any type may present an instability hazard if not secured correctly while in use or in storage. Flip top tables or training tables of any type, are inherently more unstable when folded. BRC provides the following guidelines & warnings when using mobile products:

- Lock casters immediately after moving. Do not leave the casters unlocked when in use or in storage.
- Motion may increase the instability of any item with casters. If the wheels hit an obstruction the table's forward momentum often causes overturn, especially if the item is not equipped with wheel extensions. Exercise strong caution while moving these items.
- Use caution when abrupt level changes in the floor are present (such as a doorway or room threshold) as caster failure or tipping may result.
- Do not stand, sit or lean on mobile items for support. They are not intended for this use and personal injury or property damage may result.
- Mobile units that feature height adjustable elements must be lowered to the minimum compressed height when moving to prevent instability. It is also recommended the user remove all computer equipment or other accessories to prevent possible weight imbalance or damage to equipment.
- Failure to follow the guidelines above may result in property damage or personal injury.

Heavy Load

- This product must be anchored to wall to ensure stability & safety.
- It is the owner and installers responsibility to ensure that the wall type and construction is of sufficient strength to carry the loads of any wall mounted products and their contents.
- Failure of the wall and anchors to support all imposed loads may result in property damage or personal injury.
- BRC can provide size and empty weight of its products only. As wall blocking is considered a building construction process, BRC cannot provide recommendations in this respect and cannot be responsible for damage or injury that may occur as a result of improper installation and/or blocking.

Load Bottom Drawer First!

- Operate one drawer at a time.
- Unit may tip if loaded incorrectly.
- Unit should be attached to a wall or other furniture to reduce tipping hazard.
- Always load the heaviest files in the bottom drawer.
- Failure to follow the guidelines above may result in property damage or personal injury.

11/2022