

INSTALLATION INSTRUCTIONS

CONVERTING 3 LEG T-STYLE BASE TO 3 LEG C-STYLE BASE

STEP 1: REMOVE AND DISCARD THE SIDE SUPPORT SHORT (ITEM#7) AND SIDE SUPPORT LONG (ITEM#3) FROM THE FRAMEWORK ON THE T-LEG CONFIGURATION.

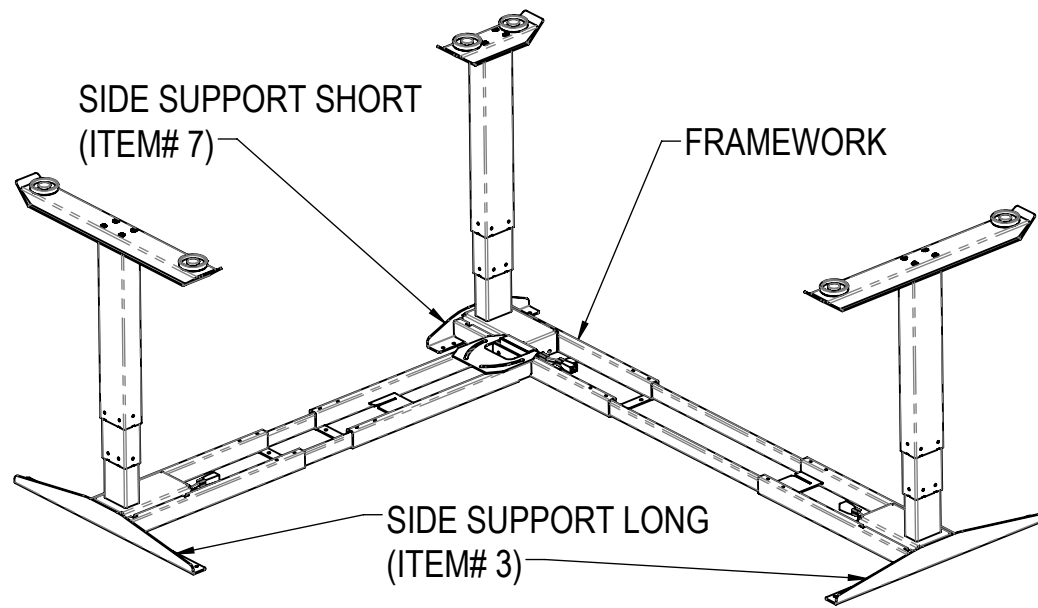

STEP 2: REMOVE AND DISCARD THE CENTER BRACKET BY UNSCREWING THE THUMB SCREWS.

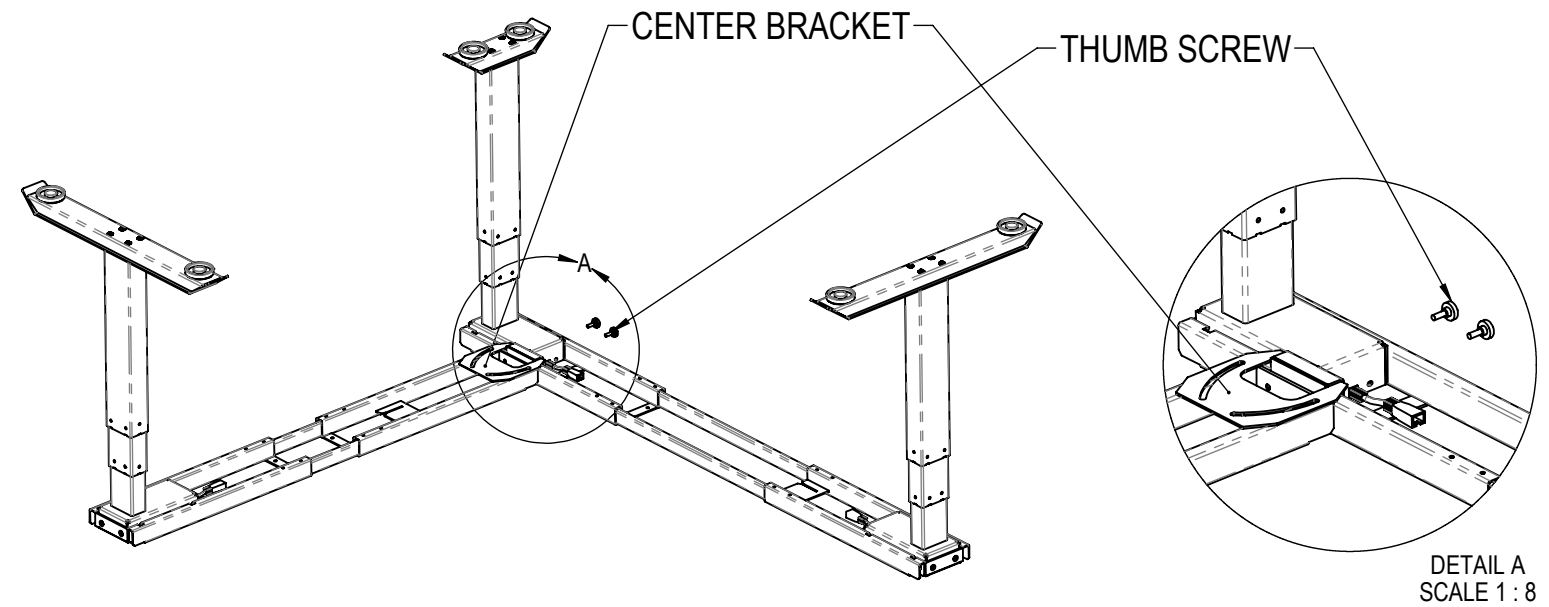

STEP 3: UNSCREW BOLTS (ITEM# 19) AND WASHERS (ITEM# 18) FROM EACH T-FEET.

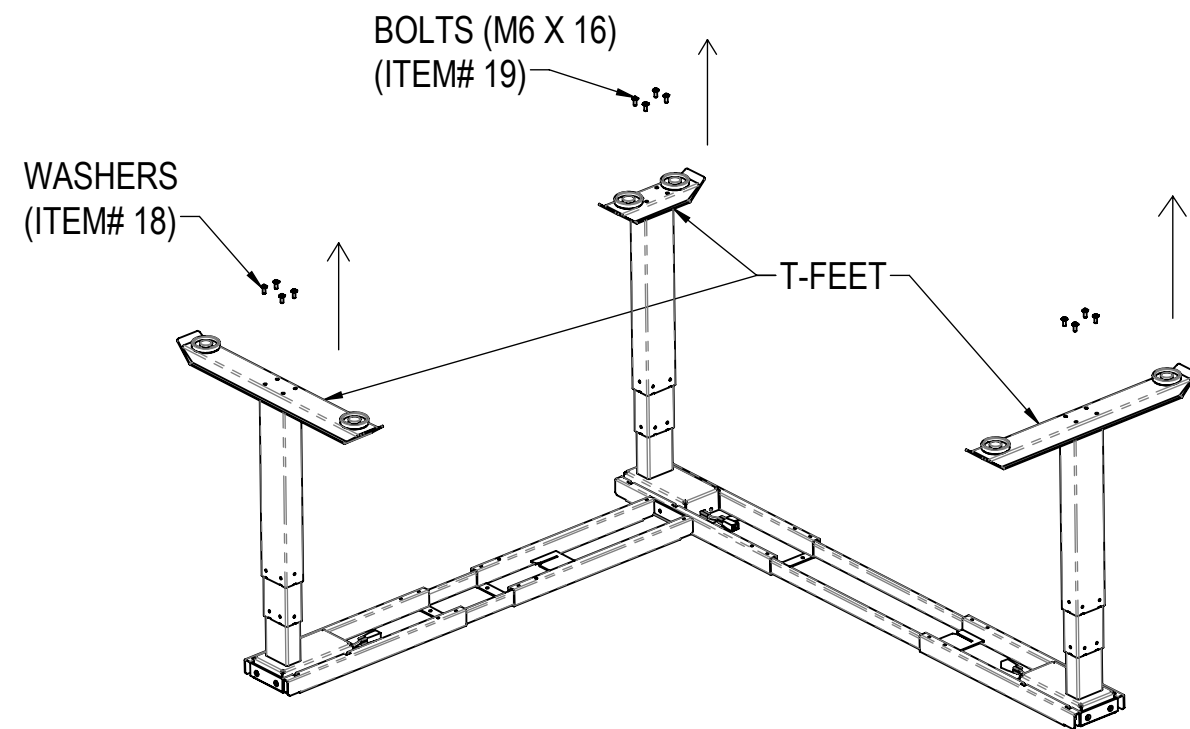

STEP 4: ATTACH THE C-FEET USING BOLTS (ITEM# 19) AND WASHERS (ITEM# 18).

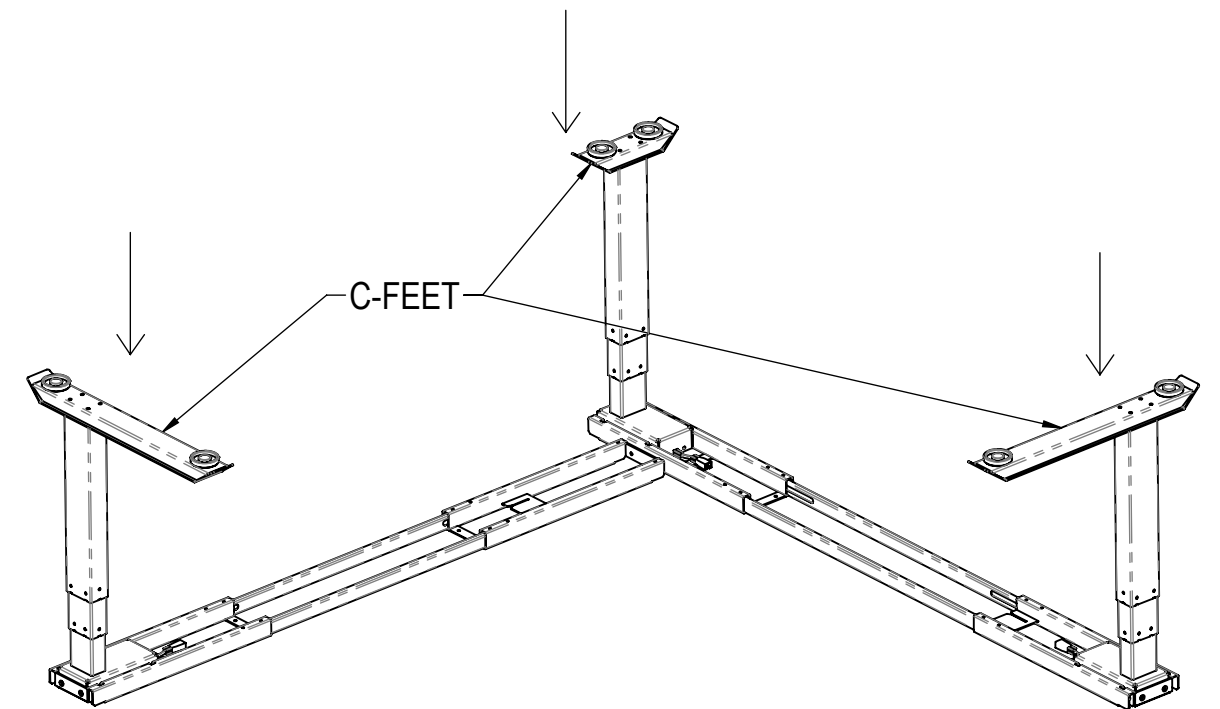

INSTALLATION INSTRUCTIONS

CONVERTING 3 LEG T-STYLE BASE TO 3 LEG C-STYLE BASE

STEP 5: INSTALL THE SIDE SUPPORT LONG (FOR C-LEG) INTO THE FRAMEWORK.

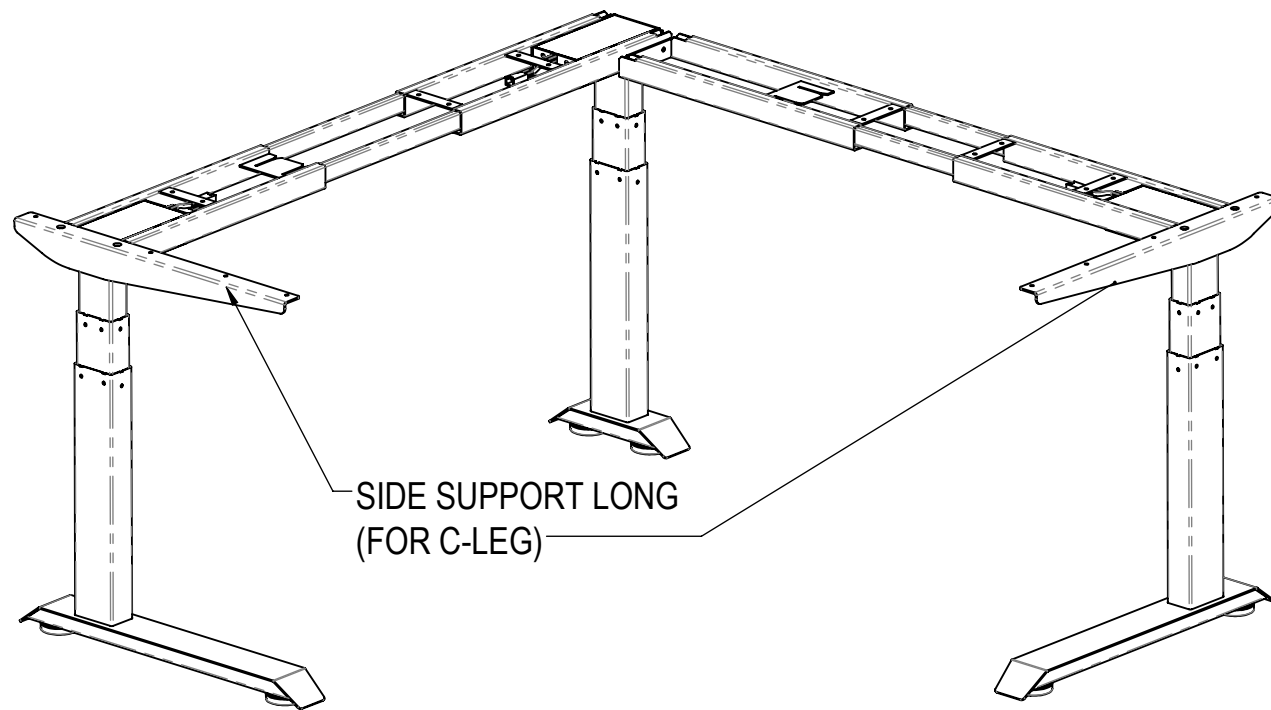

STEP 6: ALIGN BOTH THE FRAMEWORKS SUCH THAT IT'S FLUSH ON THE CORNER.

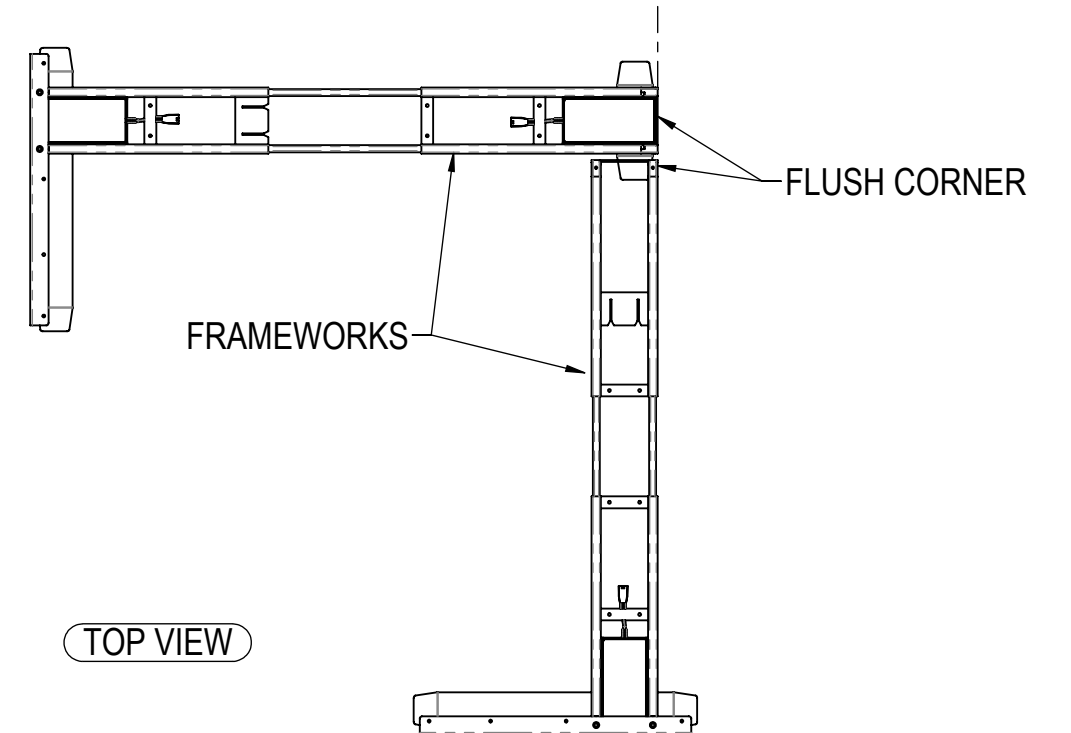

STEP 7: INSTALL THE L-BRACKET (ITEM# 8200179) USING M6 x 12 SCREWS ON FRAMEWORK# 1. ATTACH THE OTHER SIDE OF THE L-BRACKET TO FRAMEWORK# 2 USING M6 x 16 BOLTS, NUT AND WASHER.

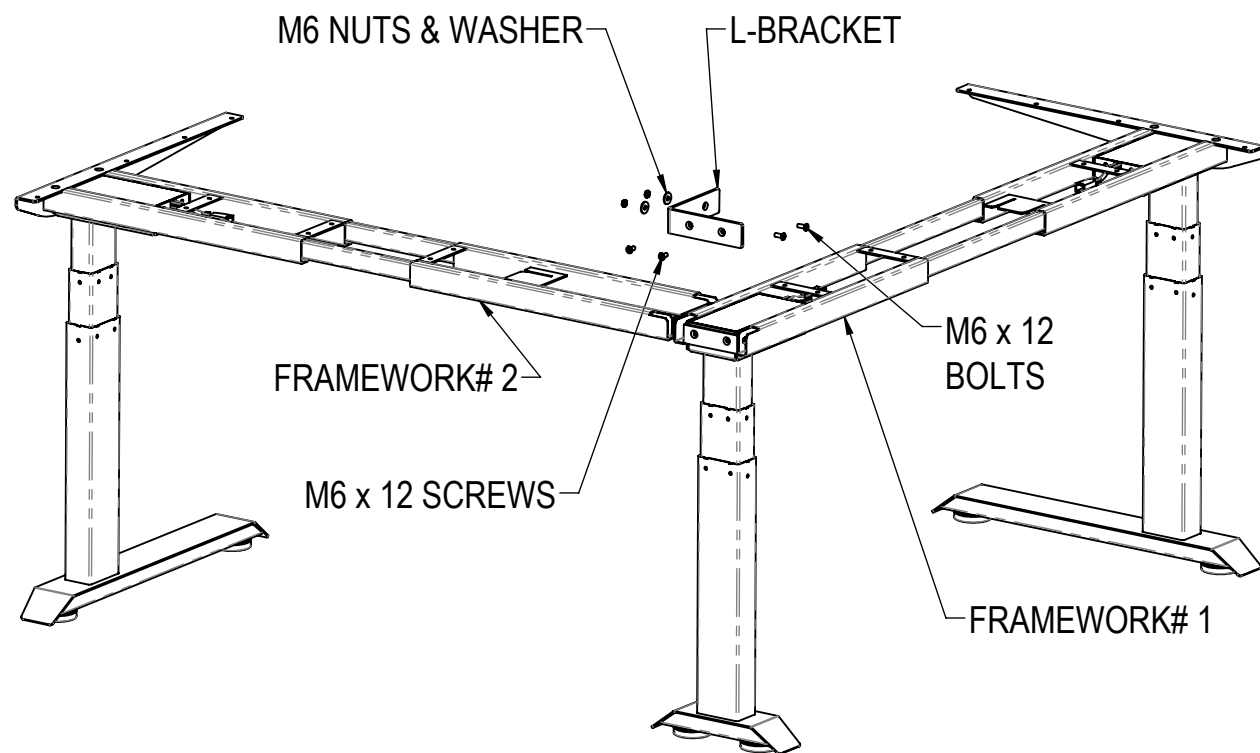

STEP 8: THE FRAMEWORK IS FULLY CONVERTED TO C-LEG CONFIGURATION. NOW ATTACH THE TOP.

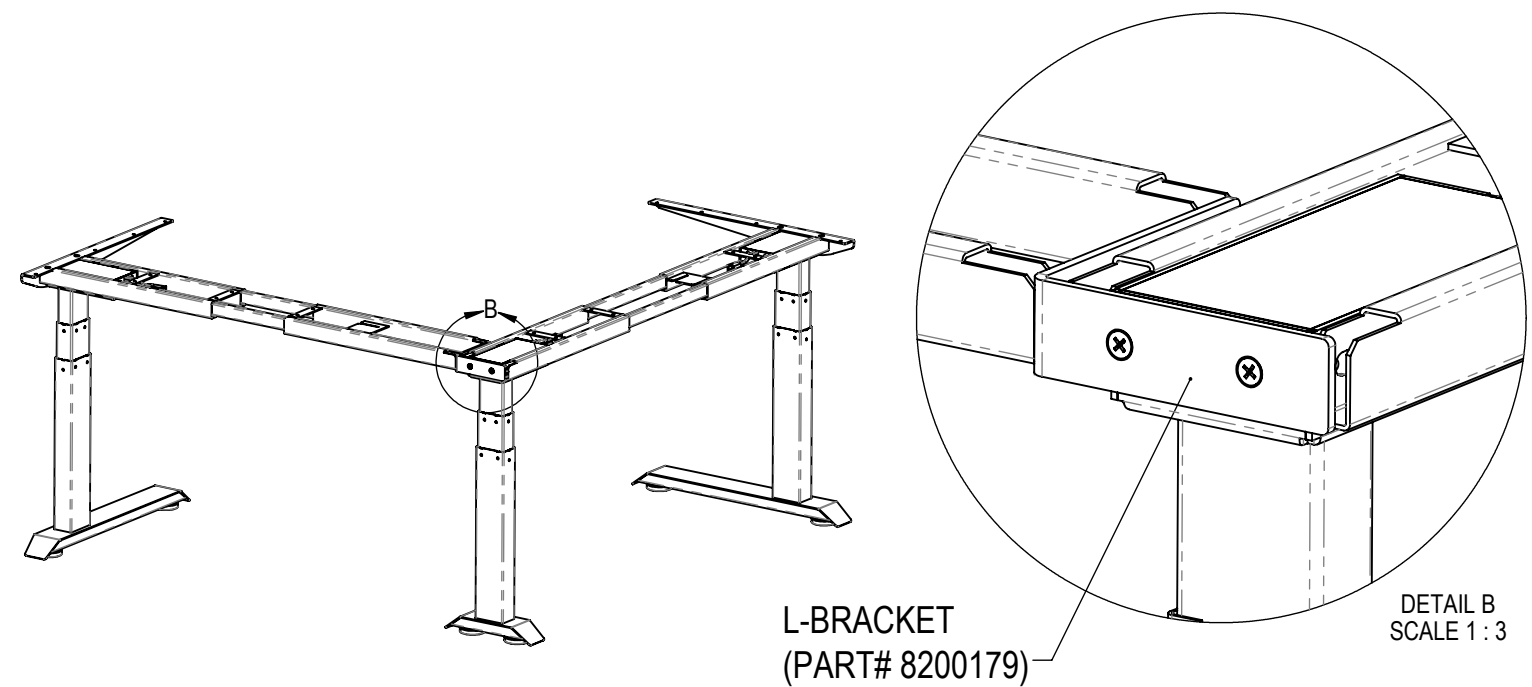



SAFETY NOTICE

Instability Hazard

Mobile items on casters such as flip top, personal and movable tables of any type and storage items of any type may present an instability hazard if not secured correctly while in use or in storage. Flip top tables or training tables of any type, are inherently more unstable when folded. BRC provides the following guidelines & warnings when using mobile products:

- Lock casters immediately after moving. Do not leave the casters unlocked when in use or in storage.
- Motion may increase the instability of any item with casters. If the wheels hit an obstruction the table's forward momentum often causes overturn, especially if the item is not equipped with wheel extensions. Exercise strong caution while moving these items.
- Use caution when abrupt level changes in the floor are present (such as a doorway or room threshold) as caster failure or tipping may result.
- Do not stand, sit or lean on mobile items for support. They are not intended for this use and personal injury or property damage may result.
- Mobile units that feature height adjustable elements must be lowered to the minimum compressed height when moving to prevent instability. It is also recommended the user remove all computer equipment or other accessories to prevent possible weight imbalance or damage to equipment.
- Failure to follow the guidelines above may result in property damage or personal injury.

Heavy Load

- This product must be anchored to wall to ensure stability & safety.
- It is the owner and installers responsibility to ensure that the wall type and construction is of sufficient strength to carry the loads of any wall mounted products and their contents.
- Failure of the wall and anchors to support all imposed loads may result in property damage or personal injury.
- BRC can provide size and empty weight of its products only. As wall blocking is considered a building construction process, BRC cannot provide recommendations in this respect and cannot be responsible for damage or injury that may occur as a result of improper installation and/or blocking.

Load Bottom Drawer First!

- Operate one drawer at a time.
- Unit may tip if loaded incorrectly.
- Unit should be attached to a wall or other furniture to reduce tipping hazard.
- Always load the heaviest files in the bottom drawer.
- Failure to follow the guidelines above may result in property damage or personal injury.

11/2022