

# PART IDENTIFICATION

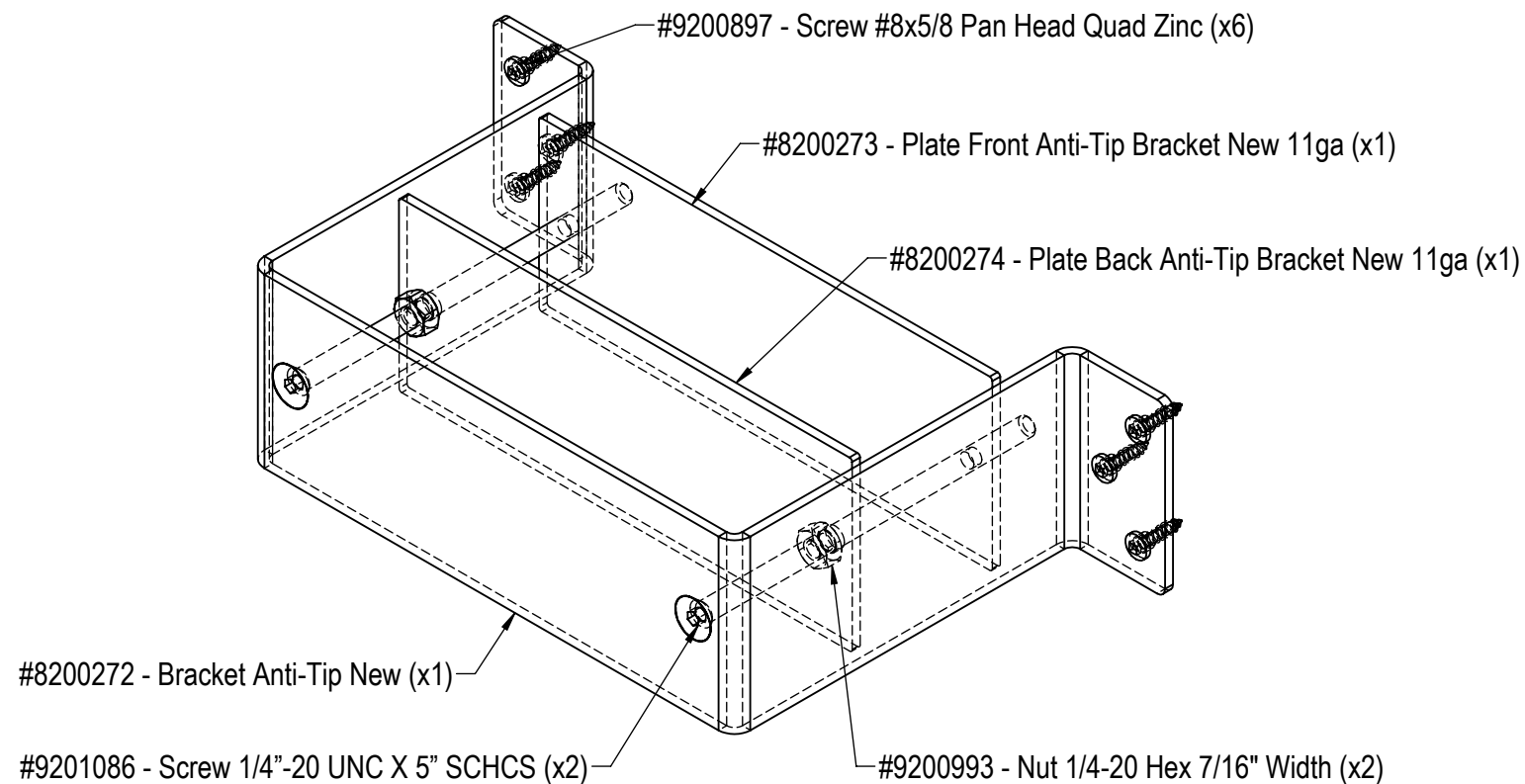

STEP 1: PLACE THE BACK PLATE (#8200274) AGAINST THE EXTERIOR FACE OF THE LEG. INSERT THE NUTS (#9200993) INTO THE 5" LONG SCREWS (#9201086) AND PASS THE SCREWS THROUGH THE ANTI-TIP BRACKET (#8200272) AS SHOWN.

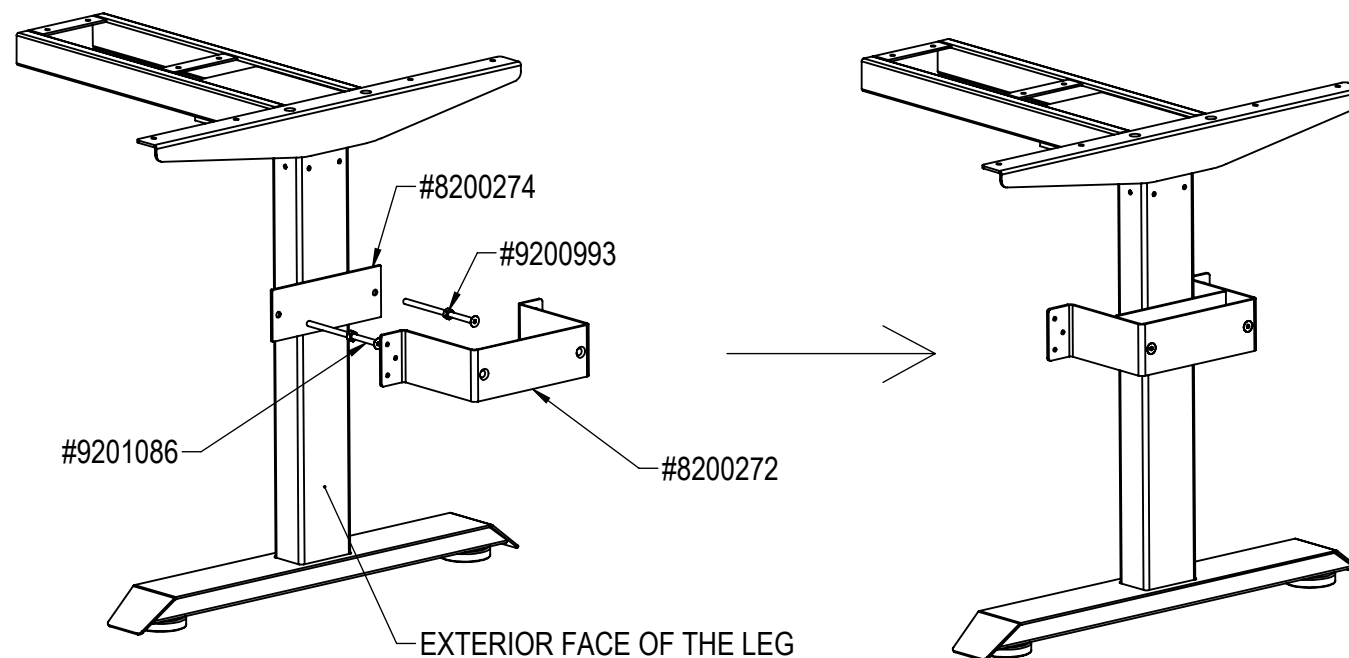

EXPLODED VIEW

ASSEMBLED VIEW

STEP 2: INSERT THE FRONT PLATE (#8200273) THROUGH THE 5" SCREWS (#9201086) AND POSITION IT AGAINST THE INTERIOR FACE OF THE LEG. THE FRONT PLATE IS THREADED, SO TIGHTEN THE SCREWS TO SECURE THE PLATE TO THE BRACKET ASSEMBLY.

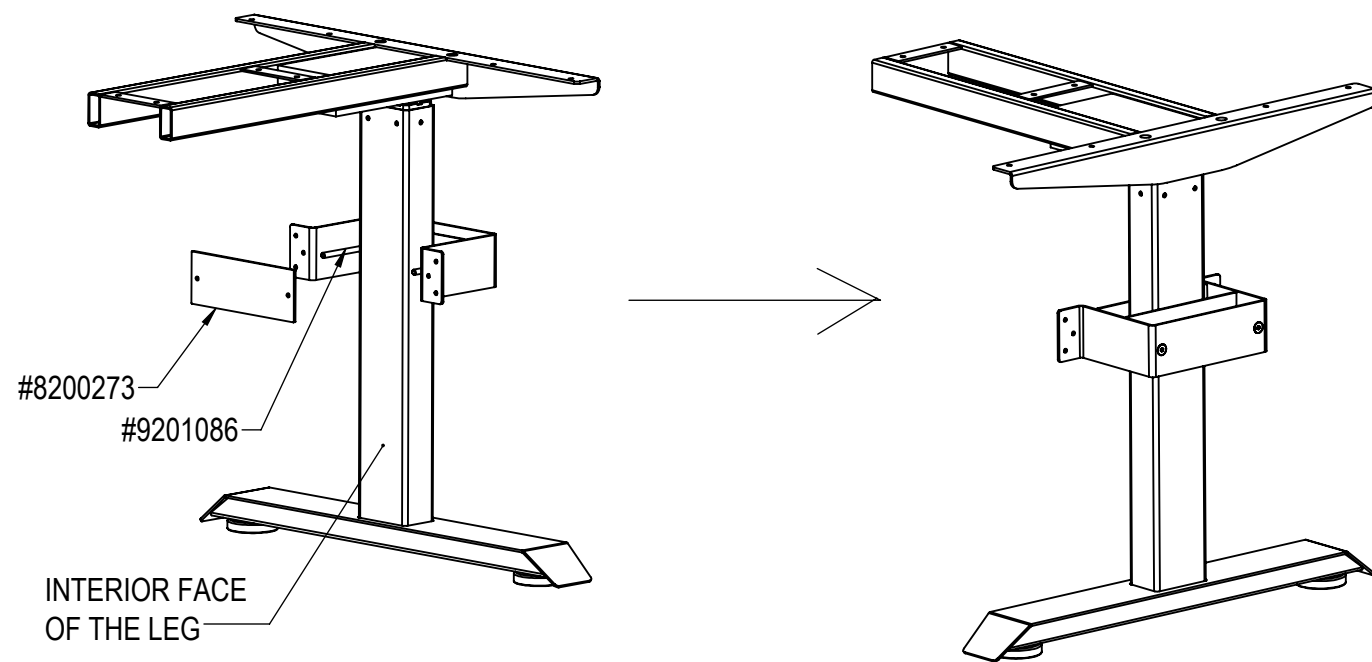

EXPLODED VIEW

ASSEMBLED VIEW

STEP 3: ONCE THE BRACKET IS ASSEMBLED, ATTACH IT TO THE LEG SURROUND USING #8 X 5/8" SCREWS (#9200897). POSITION THE BRACKET APPROXIMATELY ONE-THIRD OF THE WAY UP THE HEIGHT OF THE SURROUND. AFTER SECURING THE BRACKET TO THE LEG SURROUND, REINSTALL THE REMOVABLE PANEL TO COMPLETE THE ASSEMBLY.

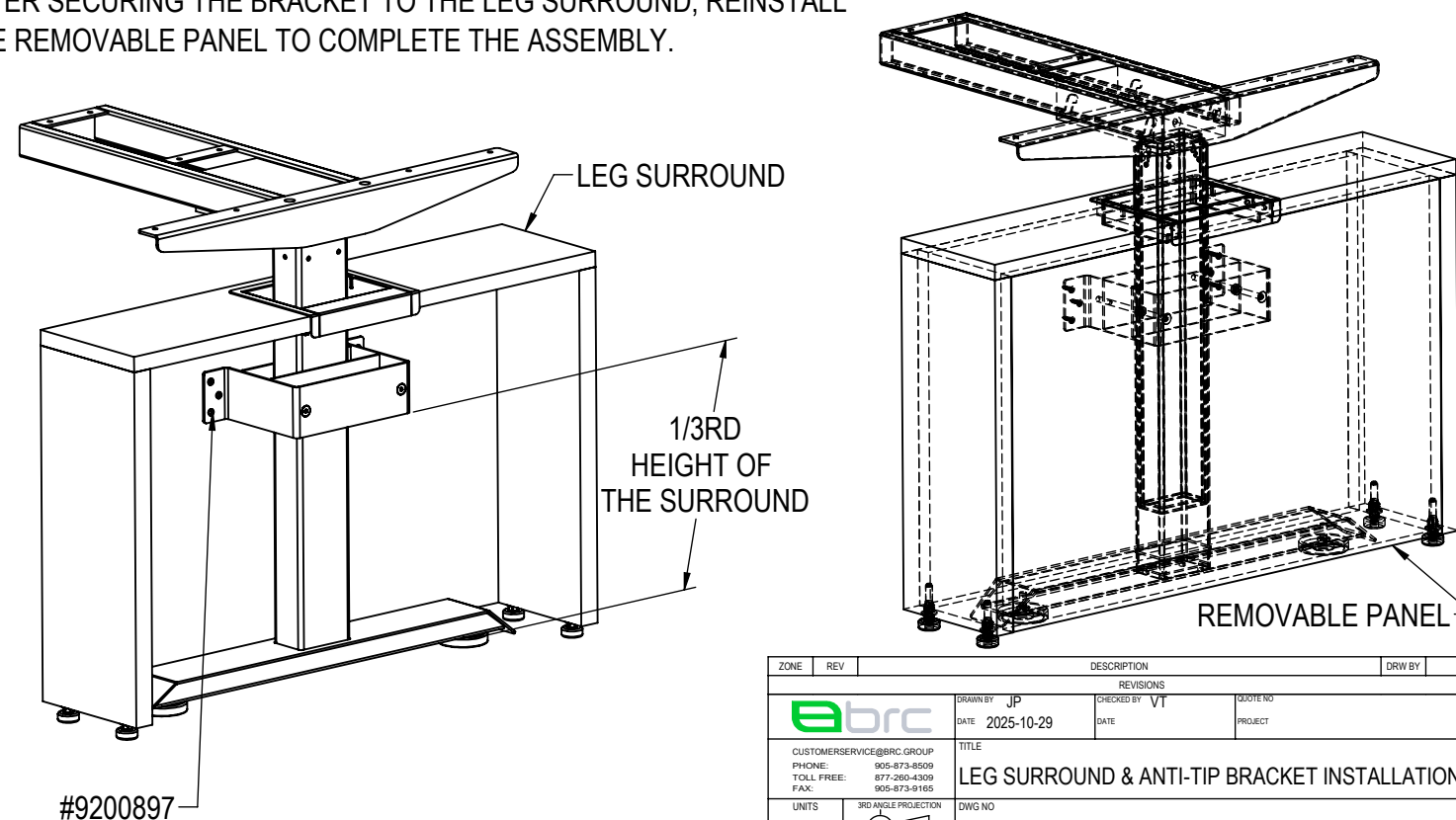

ZONE	REV	DESCRIPTION	DRW BY	DATE
eBRC		REVISIONS	DATE	DATE
CUSTOMERSERVICE@BRC.GROUP		DATE	2025-10-29	DATE
PHONE: 905-873-8509		TITLE		
TOLL FREE: 877-290-4309		LEG SURROUND & ANTI-TIP BRACKET INSTALLATION		
FAX: 905-873-8166		PROJECT		
UNITS	METRIC	3RD ANGLE PROJECTION	DWG NO	ORDER NO
SHEET	SCALE	SIZE	CUST PO	CUSTOMER
1 OF 1	1:9	A		